

PI 1099

PI 1099

Machine Dimensions Genel Ölçüler

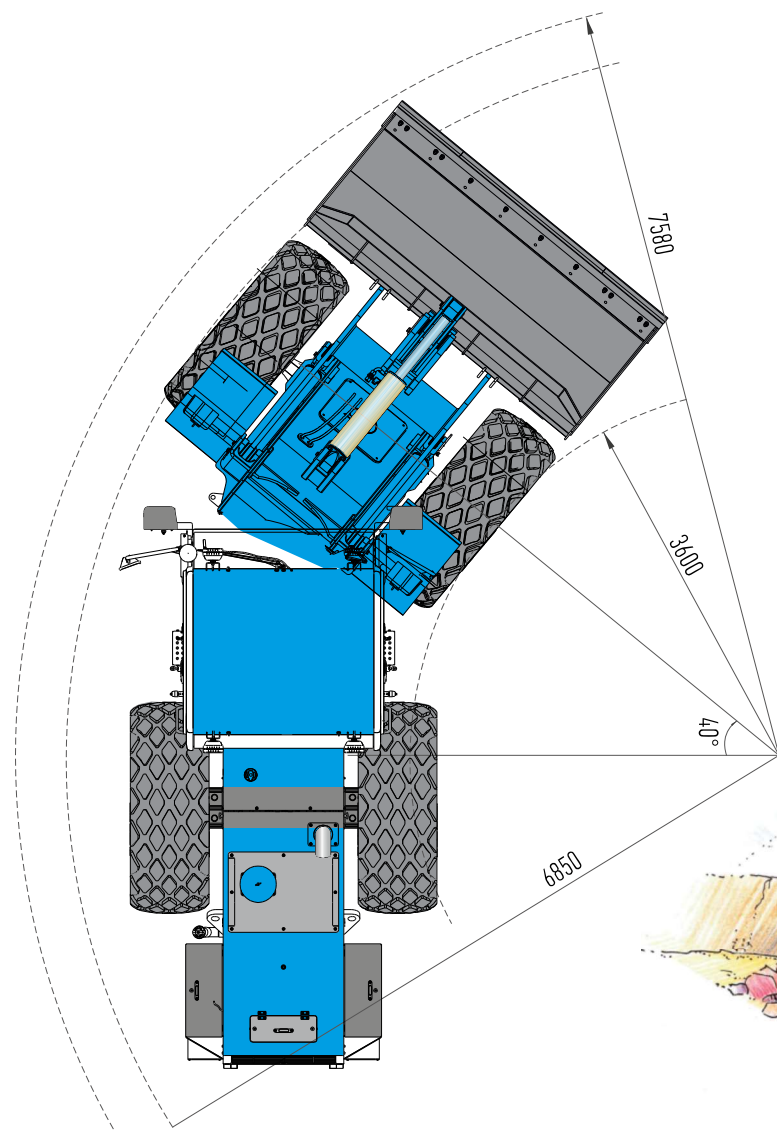
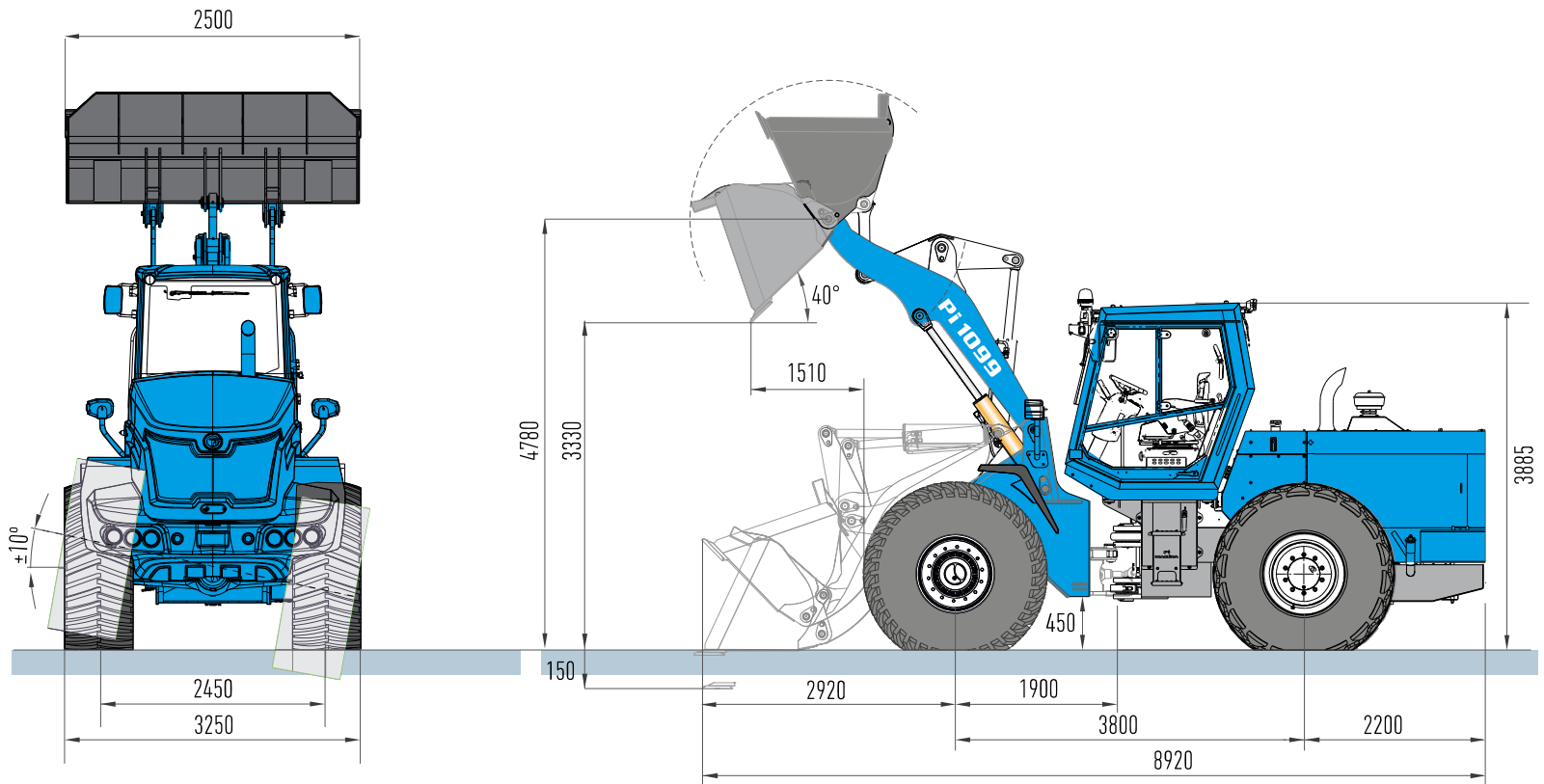

Specifications Özellikler



Motor

Engine

| | |
|--|--|
| Tip Type | Direction injection, water cooled, 4-cycle diesel engine with turbocharger |
| Hacim ve Silindir Sayısı Disp. and No. of Cylinders | 6 @ 18,9 lt |
| Güç Power | 335 kW (450 HP) @ 2100 rpm |
| Çap ve Strok Bore and Stroke | 159 mm x 159 mm |
| Azami Tork Max Torque | 1831 N.m @ 1500 rpm |



Hidrolik Sistem Hydraulic System

| | |
|--|---|
| Pompa Tipi Pump Type | Paletli Vane |
| Çalışma Basıncı Operating Pressure | 160 bar |
| Kapasite Flow Rate | 610 lt per min |
| Kaldırma Silindirleri Lifting Cylinders | 230 mm x 1070 mm (çap x strok) (bore x stroke) |
| Devrilme Silindirleri Tilting Cylinders | 210 mm x 850 mm (çap x strok) (bore x stroke) |



Akslar

Axles

| | |
|-----------------------|---|
| Tip Type | 4x4 Yürüyüş sistemi Four Wheel Drive |
| Ön Aks Front Axle | Sabit Ön Aks Rigid Front Axle |
| Arka Aks Rear Axle | Arka Aks Salınımı $\pm 10^\circ$ (toplam 20°) Rear Axle Oscillation $\pm 10^\circ$ (total 20°) |



Direksiyon Sistemi Steering System

| | |
|--|---|
| Direksiyon Sistemi Steering System | Hydrostatik direksiyon. Belden kırma şase. Hydrostatic Steering. Articulated Frame |
| Pompa Tipi Pump Type | Paletli Vane |
| Çalışma Basıncı Operating Pressure | 130 bar |
| Kapasite Flow Rate | 210 lt per min |
| Silindirler (çap x strok) Cylinders (bore x stroke) | 120 mm x 438 mm |



Teknik Özellikler Technical Properties

| | |
|--|--------------------|
| Kepçe Kapasitesi Bucket Capacity Heaped | 8,0 m ³ |
| Toplam Ağırlığı Operating Weight | 39.500 kg |
| Koparma Kuvveti Breakout Force | 26.650 kg |
| Yerden Yükseklik Ground Clearance | 450 mm |



Şanzıman

Transmission

| | | |
|------------------------------------|---|---|
| Şanzıman Tipi Transmission Type | Powershift | |
| Yürüyüş Freni Travel Brakes | Hava-Hidrolik Disk Freni Air-Hydraulic Disc Brake | |
| Park Freni Park Brakes | Kampana tipinde ön aksa mekanik kumanda Front axle in drum type, mechanical controlled | |
| Hız Speed | 1. Vites 1 th Gear | 5,7 km/h ileri / forward geri / reverse |
| Hız Speed | 2. Vites 2 nd Gear | 10,8 km/h ileri / forward geri / reverse |
| Hız Speed | 3. Vites 3 rd Gear | 20,1 km/h ileri / forward geri / reverse |
| Hız Speed | 4. Vites 4 th Gear | 37,5 km/h ileri / forward geri / reverse |

